

Product Innovation

Factory Automation Solution Innovators

KRAKEN KCP-160, Semi-automatic High Speed Case Packing System with Dual or Single Pack Stations

Ideal for Manual Pack Applications Requiring Multi Product Flexibility and Portability in a Small Footprint ...(160 PPM)



System Benefits

- The cost effective high speed semi-automated option when compared to higher cost, fully automated case packing systems;
- Ideal for contract packing operations or anywhere manual pack requirements exist;
- Single or dual pack station design or in combination;
- 160 PPM;
- Small footprint (5' X 10') and ease of portability;
- Multi-flexibility to accommodate several pack patterns in the same system;
- Automatically orient, collate, index and discharge into pre-selected precision pack formats (6, 8, 12, 16, 18, 24 & 36) for ease of placement into cases;
- Accommodates a versatile range of product sizes;
- (3.5" – 8" wide, 1" - 2.5" depth, 6.4" – 10.75" high).
- Quick changeover;
- Multi-friendly ergonomics with minimal operator stress impact;
- Low power consumption requirements.

Transition your existing manual, intense packing lines in the direction of semi-automation with more efficient and innovative case packing solutions.

Features

- Three axis, motion control driven carton indexing system;
- Dual chain indexed carton delivery system, with configurable (changeover) flight configuration;
- Motion controlled carton pusher assembly;
- All enclosed extruded aluminum frame structure;
- Small operator interface for alarm display, manual control and easy product recipe selection;
- Electrical control panel, configured with standard 480V 60Hz 3 phase (option 575V 3 phase 60 Hz, 220V 60Hz 3 phase or 380V 50Hz 3 phase);
- Machine guarding with safety interlock;
- Interchangeable vane indexers and pushers to accommodate product range;

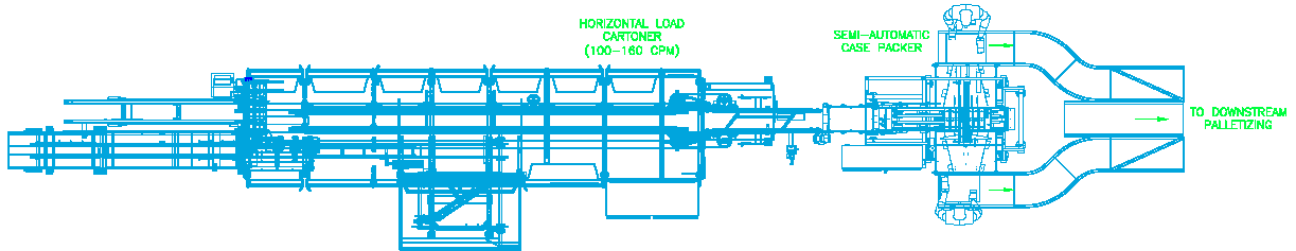
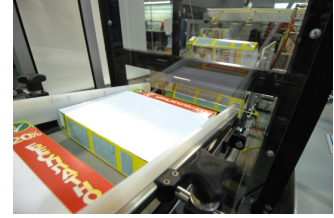

The **KRAKEN KCP-160** semi automatic case packer is a super versatile and innovative 3 axis driven motion control carton indexing, product packing station. The system employs an automated product staging infeed with collation, indexer and product pusher discharge. Products can be automatically reoriented/upended to their edge if need be, and with the use of an Operator Interface, quick selects from a variety of already pre-programmed product formats. The system, can then index in a variety of precision pack-count configurations, (6, to 18, 24 & 36) and then discharge count to single or dual packing stations on either side of the system. Operators are then able to pack products easily and accurately into to their shipping cases already in their secured count formats. This is all accomplished in a very small footprint of 5' X 10'.

Kraken's solution is ideal for transitioning current manual intense product packing lines in the direction of automation with more efficient, innovative solutions.

The KRAKEN KCP-160 is ideal for Co-packers or any other packaging operation where manual pack throughput, product/system flexibility and limited footprint are key issues.

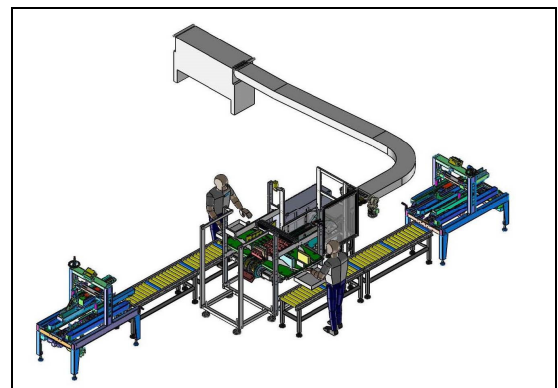
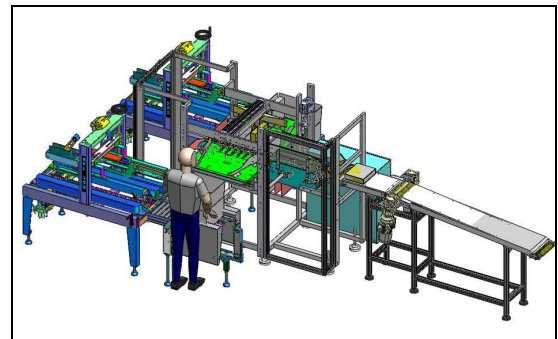

Contact us today for more information as to how Kraken Automation can assist you with our "Value Through Innovation Program" for your packaging requirements .

Kraken Automation Inc.
Tel: (905) 336-8089 or by
Email: kraken@krakenautomation.com
www.krakenautomation.com